



Charakteristika



nepřeskočitelný videospot



délka 6 sekund

Jak a kdy použít



v krátkých dynamických produktových sděleních



ve storytellingu (programmatic)



při navýšení zásahu v rámci videokampaně



když chce klient zvýšit povědomí o značce

Výhody

- ✓ Divák **uvidí celé sdělení**
- ✓ Až o **40 % cenově efektivnější** než klasický spot
- ✓ Vhodný **do mobilu**
- ✓ Zobrazuje se **u profesionálního obsahu**
- ✓ **Brand Safety**

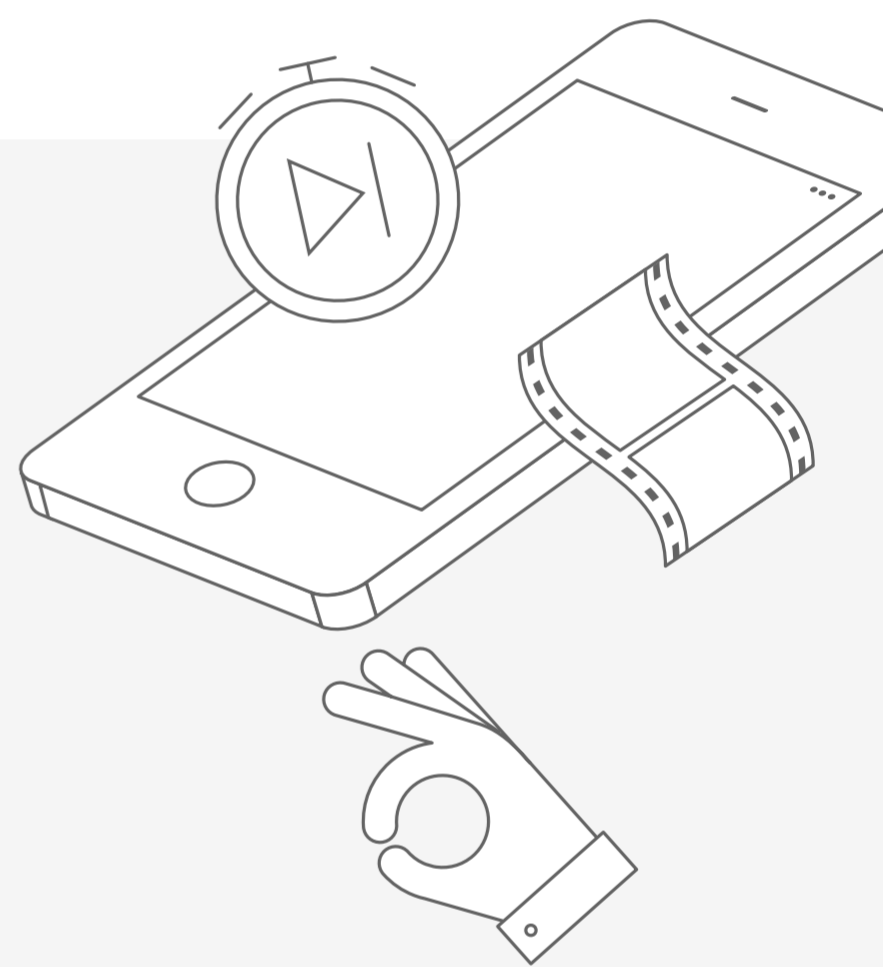

Služby, na které lze nasadit



Jak Bumper nakoupit



přímý nákup



RTB



Sklik



Velikost inventory: **30 000 000 impresí/měsíc**